

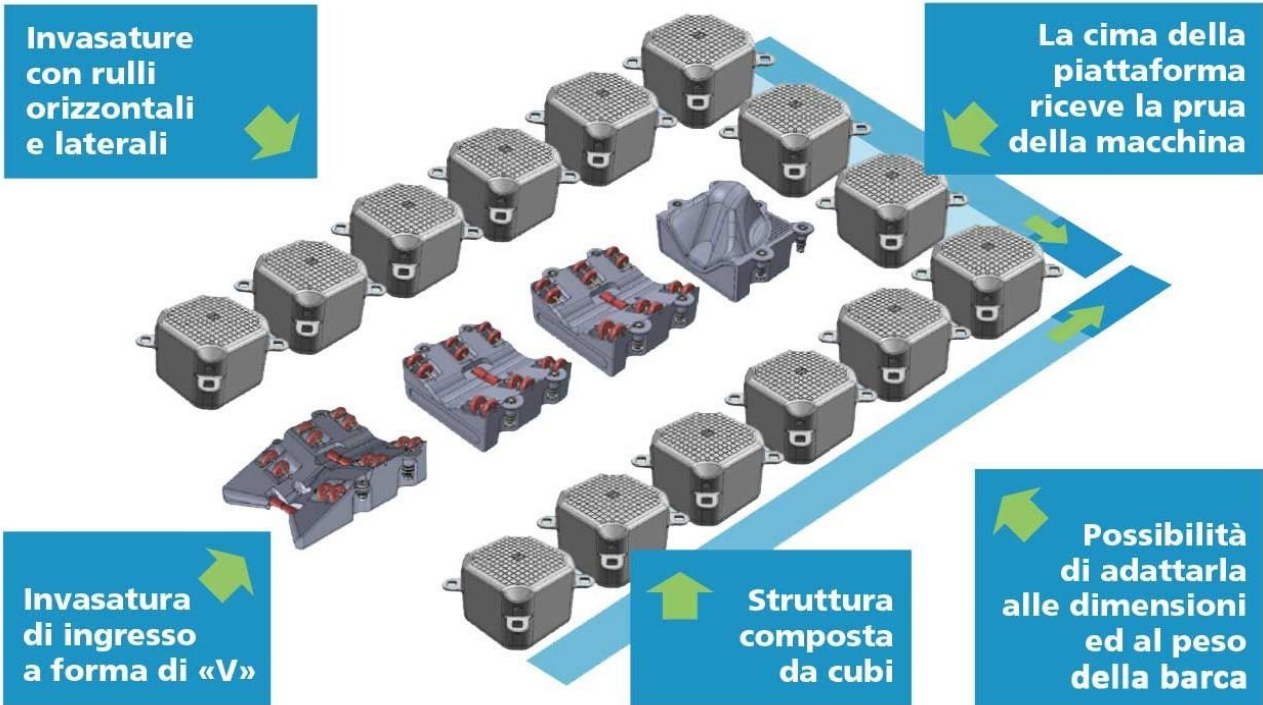

BOATLIFT

FLOATING POARTABLE PLATFORM INSTALLATION





SUPPORT PART (for boat lift big dimension to support big and heavy tender/boats)

SDS-09040/SDS-09050

The entrance support bar to the left and right side of the sunnydock cubes and put washers and nuts to the bar bolts.

The support bar should be attached to the nearest place of entrance.

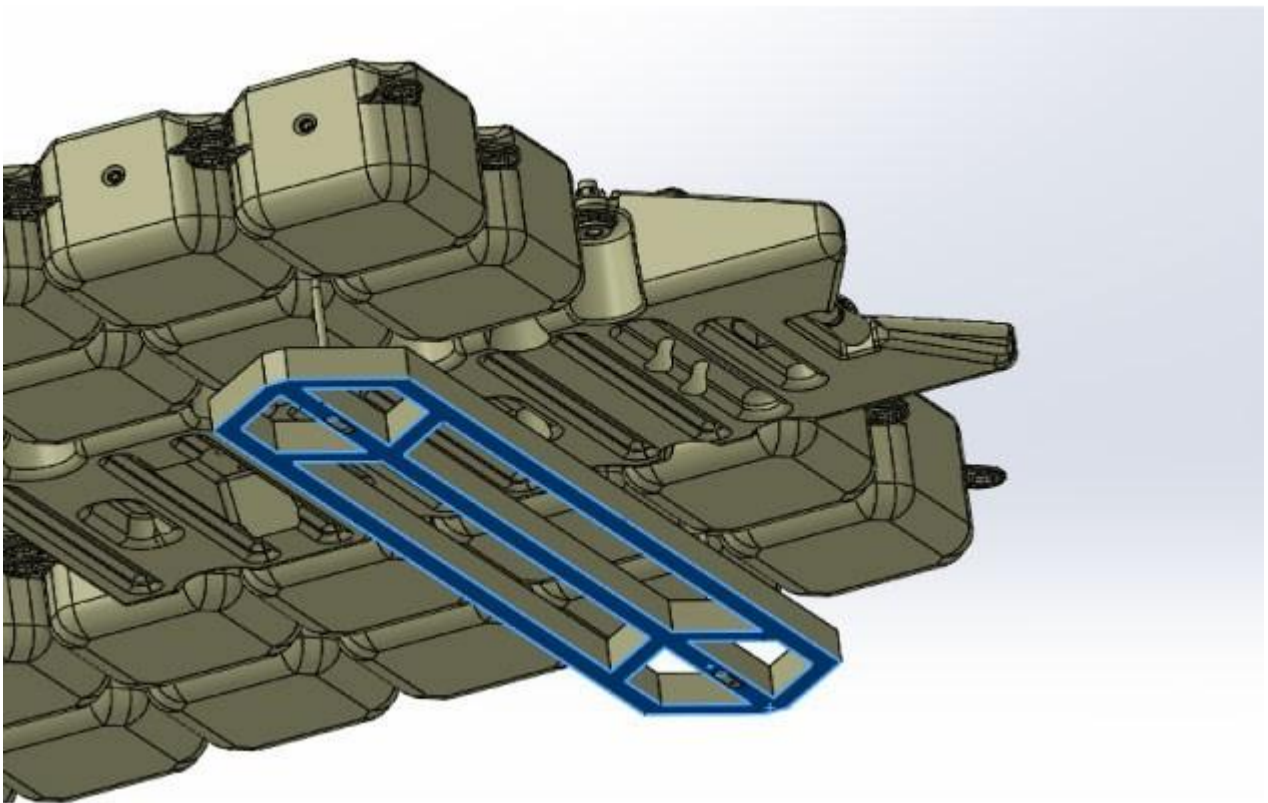
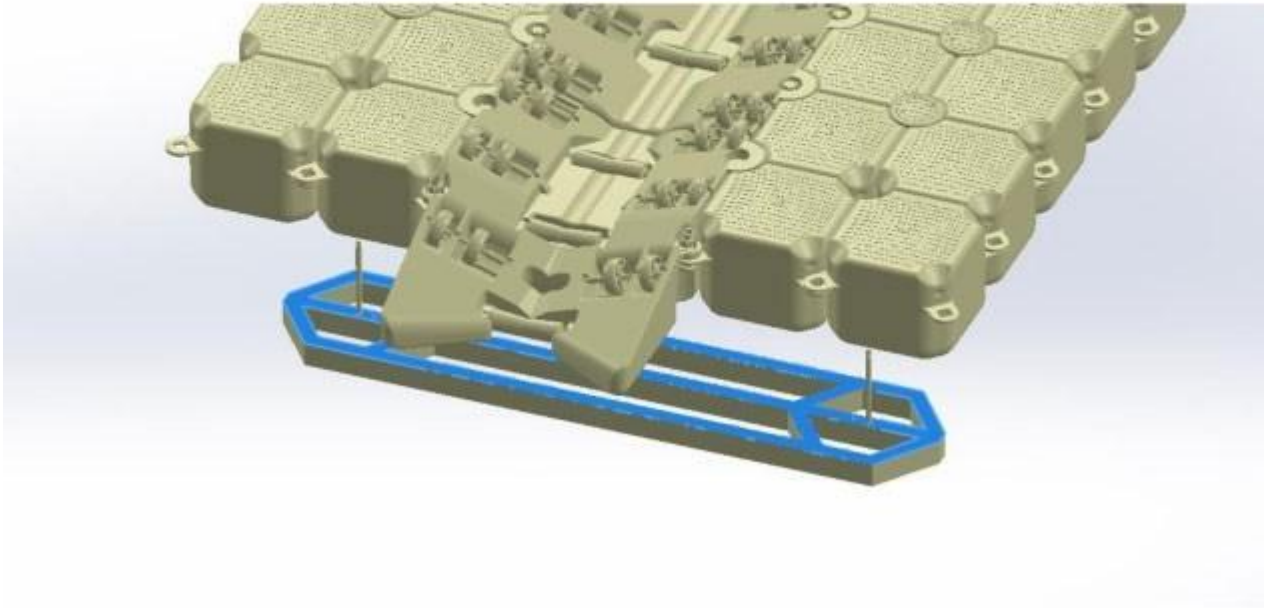

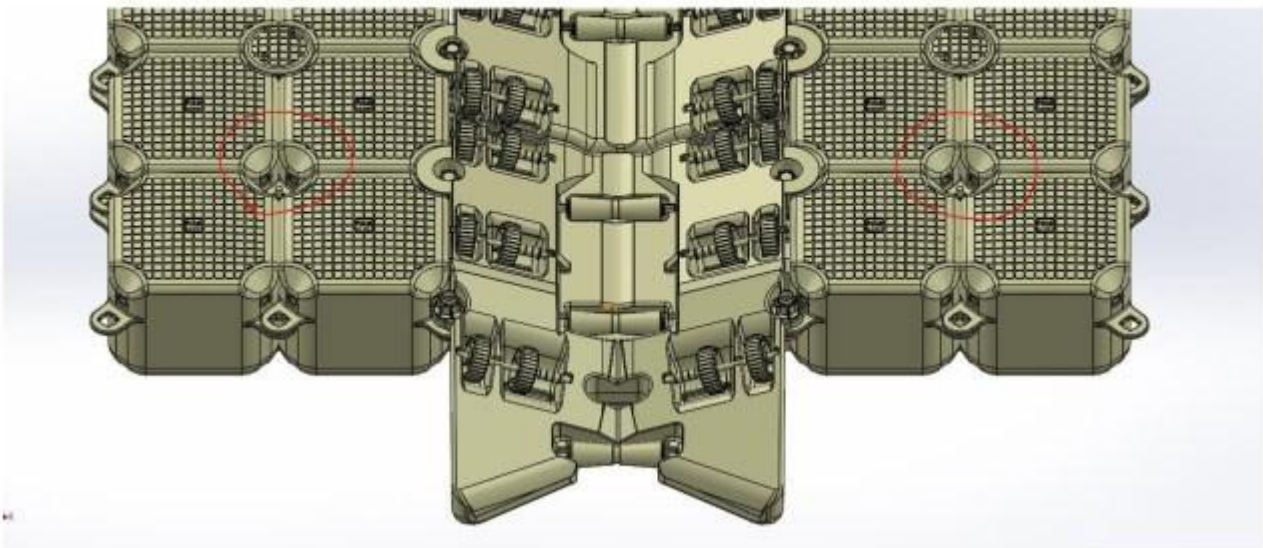
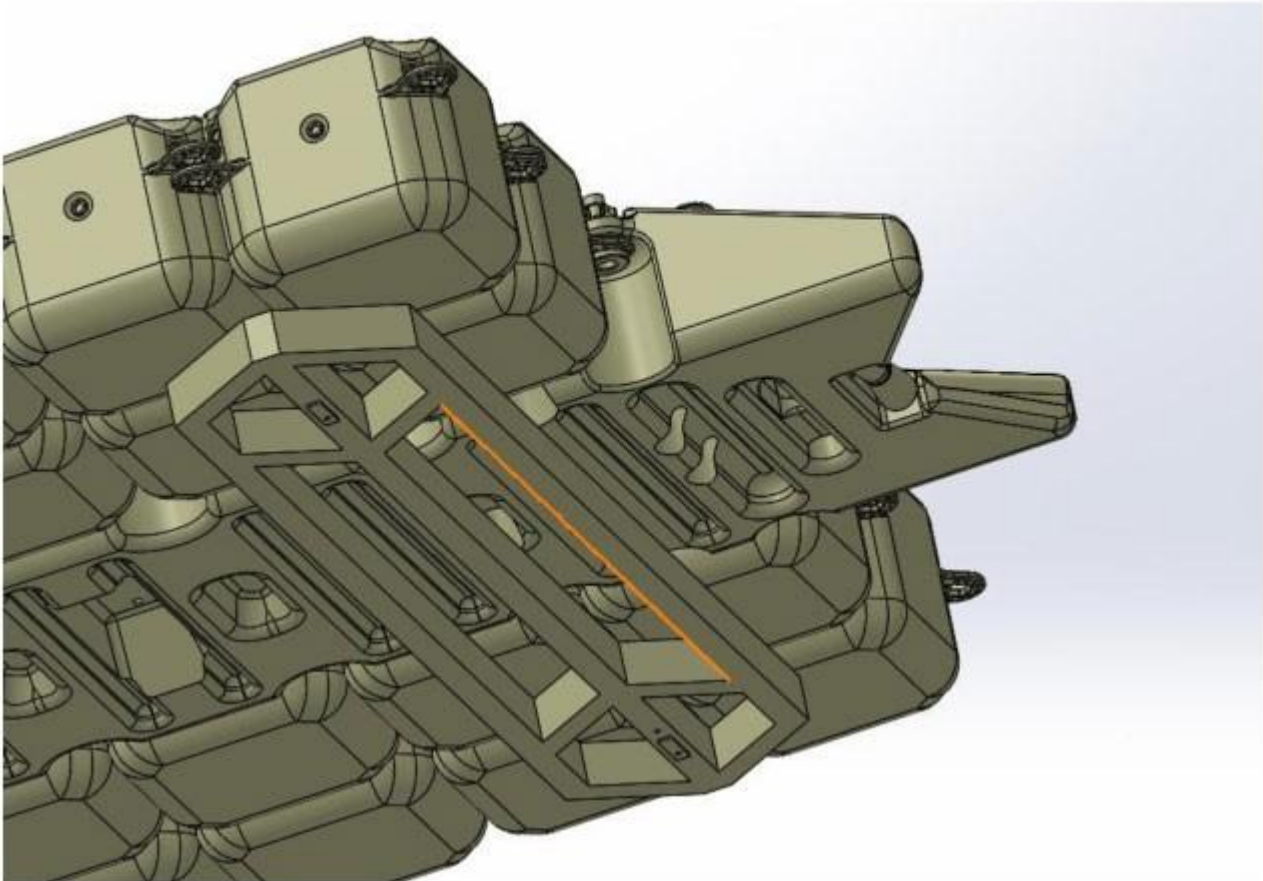



1 INSTALLATION

- Connecting the modules; after carriage of the modules/items to the installation area completed, the installation of the modules can be done on the sea if the sea conditions are available. If not, the installation should be done at the closest point to the sea on a flat surface, then the installed modules should be carried to the sea. After carrying the modules to the sea, the correctly calculated mooring items should be released in the sea and they should be anchored from the defined mooring points. The accessories (solar lights, crane, cleats, etc...) should be connected on the platform again on the sea or on the flat surface depending on the sea conditions. After the completion of the system, enough chain spaces should be left on the mooring points considering the sea and wheather conditions of the area and an installation & mooring training should be given to the related person.





BOATLIFT OPERATING&MAINTENANCE

OPERATING

After the installation and mooring of the portable platform, which is prepared with the appropriate dimensions with the boat dimensions, the boat should be taken to the uplift point of the platform and should be moved on to the platform by the help of the rollers, crane and man power.

The boat should be fixed on the platform by tying up from the cleats.

For removing the boat from the platform; it should be untied from the cleats, released from the crane, by rollers and the man power help it should be moved on the sea.

MAINTENANCE

In time, the sea creatures such as seaweed, alga, oysters might stuck on the bottom surface of the platform. In this case the platform must be washed, brushed and reinstalled.



BOATLIFT ASSEMBLING THE MODULES



1.STEP

As indicated in the above images the cubes must be assembled correctly, (the numbers on the modules should start from the small number and carry on to the bigger in the anticlockwise, the number 1 lug should be on the top).

2.STEP

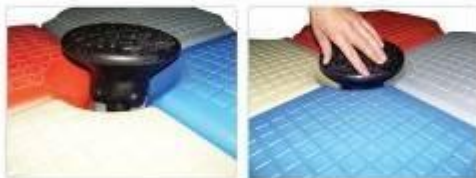

The middle pin is should be placed in the middle of the assembled cubes and it should be tighten by some pressure.

3.STEP



The gaps between the number 1 and number 4 lugs should be filled with the enough number od discs.



BOATLIFT CLEAT CONNECTION

Cleat is the accessory that we use for tying jetski, kayak, sea pedal or boat to our Dock Marine Systems platforms.

The cleats should be placed in the lugs of the cubes from the level of the number 1 lug and the washer of the side coupler set should be tightened. If the lug level is not at the number 1 lug level, the gaps must be filled with the discs.





BOATLIFT MOORING CONNECTION

The mooring sets are the anchoring items which provides to moor the platform on the sea. The chain goes through in the mooring set. The mooring sets are placed in the lugs of the cubes and tightened by the help of its bolts and nuts.

PS: To place the mooring set correctly, there must be 4 lugs together. If not, the gaps between the lugs should be filled with the discs.





BOATLIFT BODY

To be able to assemble the body in the assembled platform; firstly the bars must be placed on the main platform. Then the body should be on the fixed bars, after the the bars should be tightened from the surcafe parts by the help of washers.

PS: While placing the bars, you should be careful about keeping the bars at the level of number 1 lug. If there is any space left between the lugs or number 1 and number 2 lugs are missing the assembling should be completed by filling the gaps with the discs.





BOATLIFT SOLAR LIGHT POST

To be able to place the solar light and crane post; the middle pins should be removed and the posts should be placed into the right gaps. After placing the posts, the modules must be turned and the screws and the washers should be fastened.

PS: To simplify the process; the cubes which the posts will be assembled in should be disconnected from the main platform and the posts should be placed and then the cubes with the posts should be assembled to the main platform again.







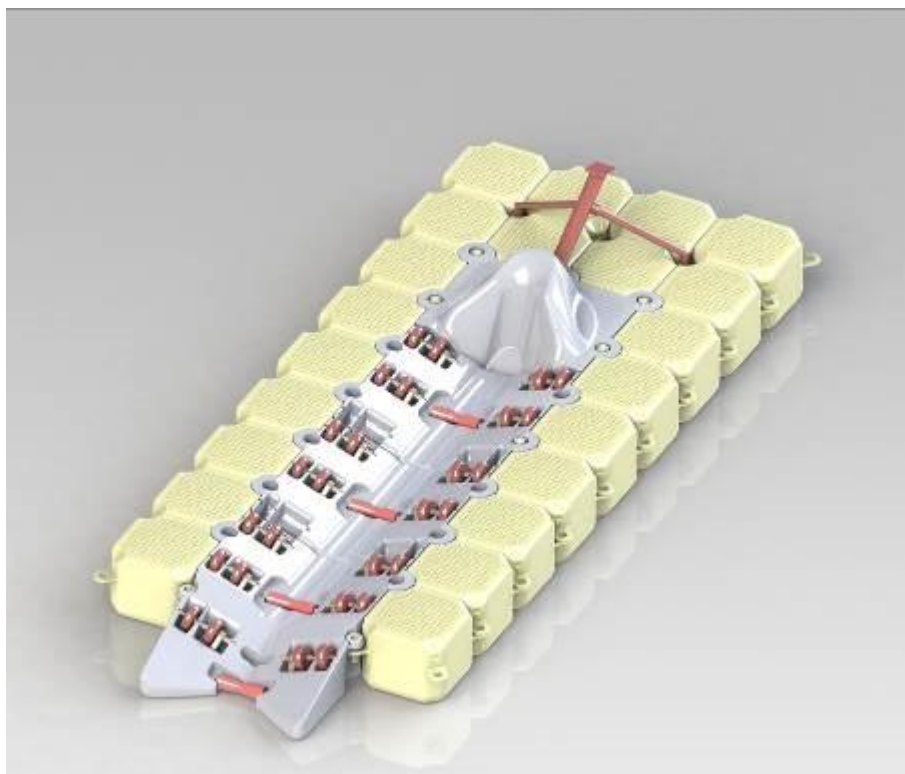

PER VIDEOS E FOTOGRAFIE VISITARE LA NOSTRA PAGINA WEB DEDICATA:

FOR VIDEOS AND PHOTOGRAPHS VISIT OUR DEDICATED WEB PAGE:

https://www.piemme-italia.com/boat_lift.html